

M-M1 Cutaway Drawing

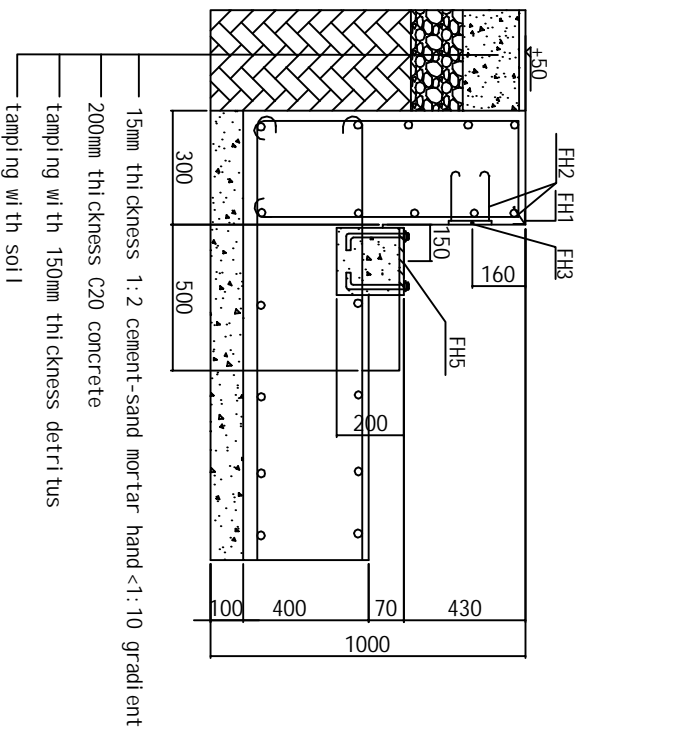

M-M2 Cutaway Drawing

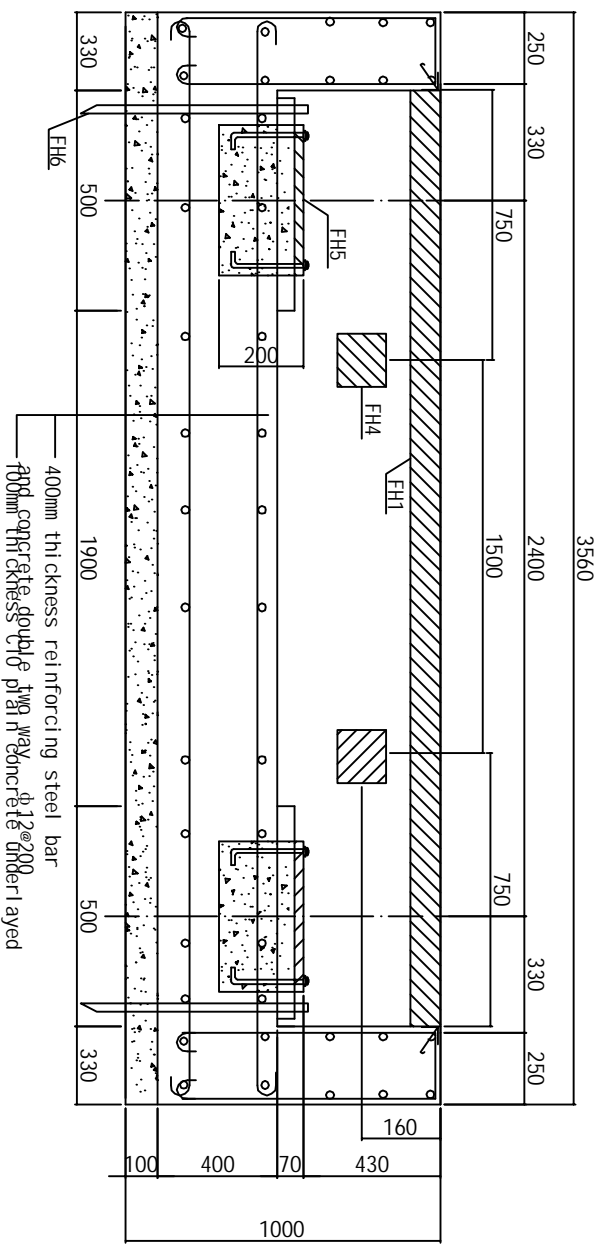

Remark

Symbol	Symbol	Explanation
✓	FH1	square steel (50 * 50 * 5mm)
⌋	FH2	100xø 8 round steel bended to hooks
□	FH3	Limit board (6*150*150mm) welding 4PCS FH2
▨	FH4	Specification of Limit board same as FH3 embedding 4PCS
⌋	FH5	16*300*300mm of load-bearing plate welding 4 PCS M4*150 bolt to fix
—	FH6	Conductive pole, dimensions ≥φ12, length ≥1250mm

- All figures in the pictures are millimeter for the unit, height of natural floor ±0
- Designed foundation bearing capacity $\geq 60\text{kn/m}$
- Concrete \pm C20, "Hoop steel" of reinforcing steel bar should be round steel, others whorl steel, underlay C10 concrete 100mm thickness
- Reinforce foundation according to carrying capacity of local soil and water level to avoid the foundation to go down, our pictures are just for your reference.
- Relative error of centre of each bearing plate (front and back, left and right, diagonal) $\leq 10\text{mm}$
- Surface of every bearing plate at the same level, error $\leq 3\text{mm}$, suggesting bearing plates irrigated twice to keep accuracy.
- Embedding hollow plastic pipes at the same time with foundation construction.
- The foundation plate should be higher in the middle, lower at both sides to facilitate drainage (suggesting drainage holes use $\phi 150$ pipes' single-hole or porous)
- Conductive pole embedded next to foundation, and some buried near the pound house, indicator separately grounding (dimension of conductive pole $\geq \phi 12$, depth of embedding $\geq 1200\text{mm}$, outer from cement ground 50mm).

Design	Audited	Shanhe Scale Co. Ltd.	Page 2
Draw	Audited	SCS- 3m x 21 m	Page 2
Correct	Date	Pit Foundation Draw	Page 2