

Design	Audit	Shanhe Scale Co.Ltd.	
Draw	Audited	SCS- 3.m x 6m	
Correct	Date	Pit Foundation Draw	Page 1

M-M1 Cutaway Drawing

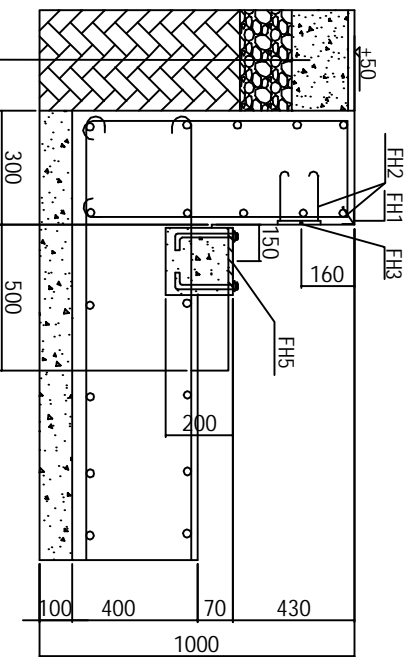

- 15mm thickness 1:2 cement-sand mortar hand < 1:10 gradient
- 200mm thickness C20 concrete
- tamping with 150mm thickness detritus
- tamping with soil

M-M2 Cutaway Drawing

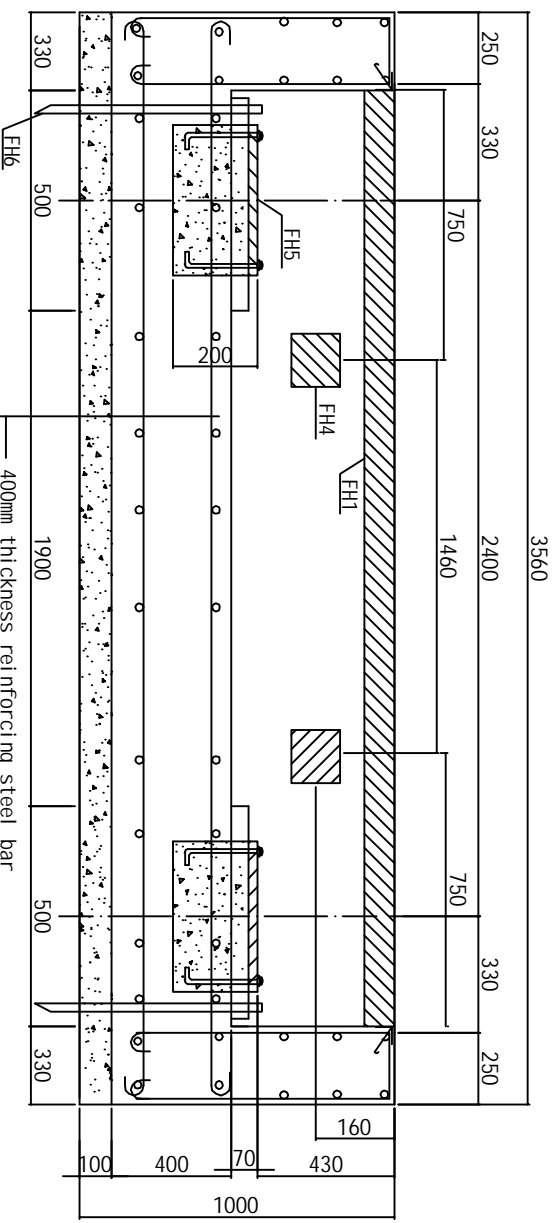

Remark

Symbol	Symbol	Explanation
↗	FH1	square steel (50 * 50 * 5mm)
—	FH2	100X∅ 8 round steel bended to hooks
□	FH3	Limit board (6*150*150mm) welding 4PCS FH2
▨	FH4	Specification of limit board same as FH3 embedding 4PCS
⌈	FH5	16*300*300mm of load-bearing plate welding 4 PCS M4*150 bolt to fix
—	FH6	Conductive pole, dimension $\geq \phi 12$, length ≥ 1250 mm

- 1 All figures in the pictures are millimeter for the unit, height of natural floor ± 0
- 2 Designed foundation bearing capacity $\geq 60\text{kn/m}^2$
- 3 Concrete \pm C20, "Hoop steel" of reinforcing steel bar should be round steel, others whorl steel, underlay C10 concrete 100mm thickness
- * 4 Reinforce foundation according to carrying capacity of local soil and water level to avoid the foundation to go down, our pictures are just for your reference.
- 5 Relative error of centre of each bearing plate (front and back, left and right, diagonal) ≤ 10 mm
- 6 Surface of every bearing plate at the same level, error ≤ 3 mm, suggesting bearing plates irrigated twice to keep accuracy.
- 7 Embedding hollow plastic pipes at the same time with foundation construction.
- 8 The foundation place should be higher in the middle, lower at both sides to facilitate drainage (suggesting drainage holes use $\phi 150$ pipes' single-hole or porous)
- 9 Conductive pole embedded next to foundation, and some buried near the pound house, indicator separately grounding (dimension of conductive pole $\geq \phi 12$, depth of embedding ≥ 1200 mm, outer from cement ground 50mm).

Design	Audit	Shanhe Scale Co. Ltd.
Draw	Audited	SCS- 3m x 6.1 m
Correct	Date	Pit Foundation Draw
		Page 2